

BATTLING CORROSION IN NUCLEAR WASTE STORAGE FACILITIES

BY GARY DAGASTINE

Multiphysics simulations helped Sogin S.p.A. design a simple, energy-efficient dehumidification system to prevent corrosion in drums of radioactive waste.

Corrosion is a relentless and unforgiving enemy of metal, and the battle against it simply cannot be lost when steel drums full of nuclear waste are involved.

Such is the situation in Italy, where domestic nuclear power production has been halted, yet the need is ongoing to safely store low-level radioactive waste produced as a byproduct of power generation, research, medical, and industrial activities.

Sogin S.p.A. is the Italian state-owned company responsible for the decommissioning of Italy's nuclear sites and the management of radioactive waste.

NUCLEAR WASTE STORAGE REQUIRES ACCURATE HUMIDITY CONTROL

One Sogin project is the ongoing renovation of a building at a former nuclear power plant located in the center of Italy. The goal is to meet Italian and international requirements for temporary storage of low-level radioactive waste until the waste can be delivered to the National Permanent Repository.

The temporary facility is an approximately 30 m x 15 m single-floor rectangular space divided into two rooms. The waste is stored in steel drums encased in concrete for radiological reasons. The drums have an external diameter of 0.8 meters, while the overpack is one meter in diameter. Relative humidity of 65

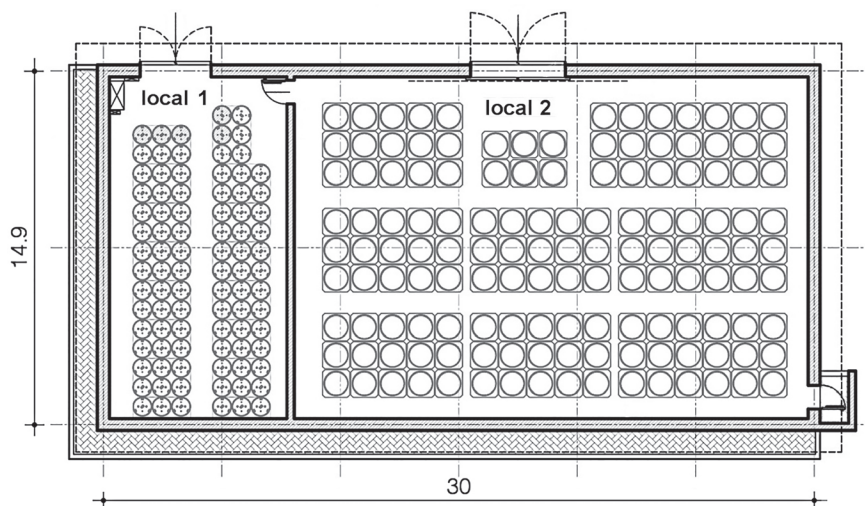

FIGURE 1. Floor plan for a space divided into two rooms and used as a temporary storage facility for low-level radioactive waste. The waste is stored in the rooms in non-stainless steel drums with a concrete overpack.

percent or lower must be maintained to prevent corrosion.

Gianluca Barbella is a Sogin structural engineer and Team Leader for the project. "The need to control air humidity is due to the non-stainless steel drums that are used. The concrete overpacks mean the drums aren't inspectable without first extracting them, which makes it difficult to constantly monitor the corrosion process. Also, the site is exposed to high levels of relative humidity. Therefore, humidity control is critical," he explains.

However, the cost of operating a heating, ventilating, and air-conditioning (HVAC) system to maintain optimum conditions over the anticipated 25-year life of the facility is substantial. In addition, because the facility can't be expanded, an HVAC system's space requirements would result in less space available for waste storage. Moreover, HVAC system downtime is inevitable because of both equipment malfunctions and scheduled maintenance.

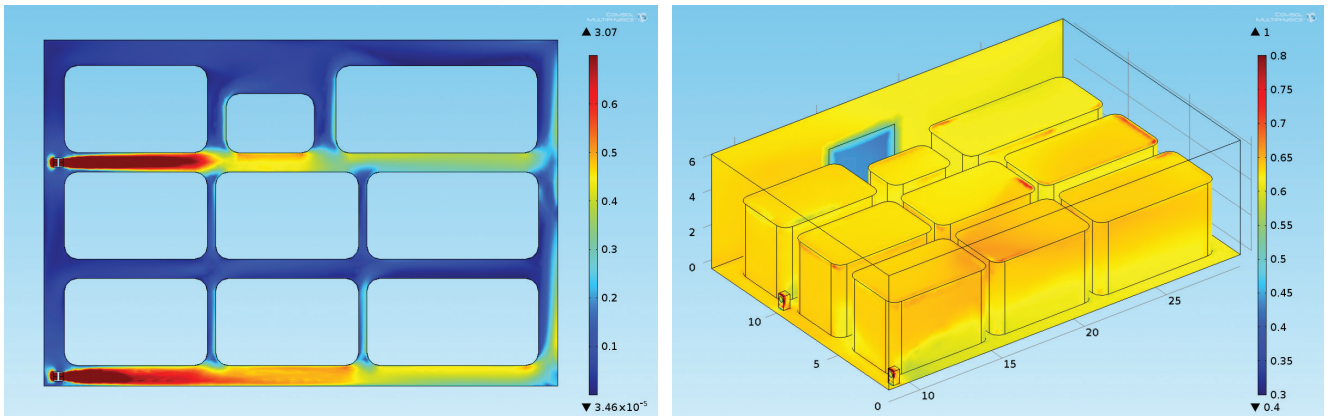

FIGURE 2. For a room designed to store radioactive waste for up to 25 years, Italy's Sogin S.p.A. used COMSOL simulations to study air flow velocities in the room (left) and surface relative humidity throughout the room (right) that would result from various dehumidifier types and locations within the space. The results helped engineers design a dehumidification system that minimizes stagnant air, enables maximum operating efficiency, and optimizes relative humidity.

A potential alternative is to use industrial isothermal dehumidifiers instead, which are relatively small, mobile, require less maintenance, and have substantially lower operating costs. These units are based on the reverse Carnot thermal cycle: A fan draws air into the unit, where it passes over an evaporator and is cooled. Excess moisture from the air condenses into drops of water that fall into a tank. The air then passes through a condenser where it is warmed by several degrees. It is then recycled into the environment as drier, warmer air.

The Sogin project relied on numerical simulation to study the impacts of various sizes and configurations of two different industrial isothermal dehumidifiers. The analyses were carried out by Piergianni Geraldini, from the mechanical design department. The goals were to identify equipment requirements and also to determine optimum placement of the units in the rooms (see Figure 1).

SIMULATIONS HELPED DETERMINE OPTIMUM LAYOUT

The team first studied turbulent air flow in the room by performing stationary fluid-flow studies based on a single-phase incompressible k-epsilon turbulence model. Its purpose was

to reproduce the air velocity field in the storage area assuming the dehumidifiers were in use.

Then they used the results from those studies in time-dependent, fully-coupled simulations to study heat and moisture transfer within the room's atmosphere (see Figure 2). The overall results were used to develop an optimum layout for the dehumidifiers.

“COMSOL Multiphysics makes it easy to couple different physics, has an intuitive interface, and opens up the possibility of managing the entire modeling process within the same interface.”

All simulations were conducted using COMSOL Multiphysics® and the Heat Transfer Module. “Without such a refined simulation tool, we would have had to model the dehumidification process using simplified approximations coupled with dehumidifier performance curves supplied by the units’ manufacturers. But the simulations showed us that COMSOL has a

powerful capability to solve 3D heat and moisture transfer problems,” says Piergianni. “COMSOL Multiphysics makes it easy to couple different physics, has an intuitive interface, and opens up the possibility of managing the entire modeling process within the same interface.

“The simulations helped us to design a layout based on the use

of two dehumidifiers that provides the same dehumidification capacity as other configurations, but they required four units,” concludes Barbella. “The system we designed will limit stagnant air pockets, enable the units to operate at peak efficiency, and help us reduce the risk of drum corrosion once the facility is finalized and commissioned.” ■