

Multi-objective Optimization of Microneedle Design for Transdermal Drug Delivery

M. Sarmadi^{1,2,*}, K. McHugh², R. Langer^{1,2,3}, A. Jaklenec²

1. Department of Mechanical Engineering, Massachusetts Institute of Technology, Cambridge, MA, USA
 2. David H. Koch Institute for Integrative Cancer Research, Massachusetts Institute of Technology, Cambridge, MA, USA
 3. Department of Chemical Engineering, Massachusetts Institute of Technology, Cambridge, MA, USA

INTRODUCTION: Transdermal drug delivery using microneedles has been recognized as an effective method, and a potential alternative for hypodermis needle injection. Despite significant advances in microfabrication techniques for high-precision manufacturing of microneedle arrays, less is known about the effect of various geometrical parameters on overall mechanical performance of microneedles. This study aims to systematically study effect of various geometrical design parameters on mechanical performance of microneedles.

COMPUTATIONAL METHODS: Structural Mechanics Module from COMSOL Multiphysics® V 5.3 in conjunction with Material Library was employed. A parametric study was performed using the results of more than 2100 simulations performed by parametric sweep feature. Critical buckling load factor (λ), maximum deflection and von Mises stress under bending and axial loading, as well as maximum deliverable drug volume were multi-objectively optimized using the following equations:

$$\lambda = \frac{P_{critical}}{P_{applied}} \quad (1)$$

$$P_{critical} = \frac{\pi^2 EI}{(KL)^2} \quad (2)$$

$$\sigma_{bending} = \frac{Mz}{I} \quad (3)$$

$$L_p(x) = \sum_{i=1}^k [w_i^p \left[\frac{f_i(x) - f_i^0}{f_{i,max} - f_i^0} \right]^p]^{1/p} \quad (4)$$

Considered Design parameters are illustrated in Figure 1 with the Boundary conditions shown in Figure 2. The microneedle was considered solid, made form PMMA.

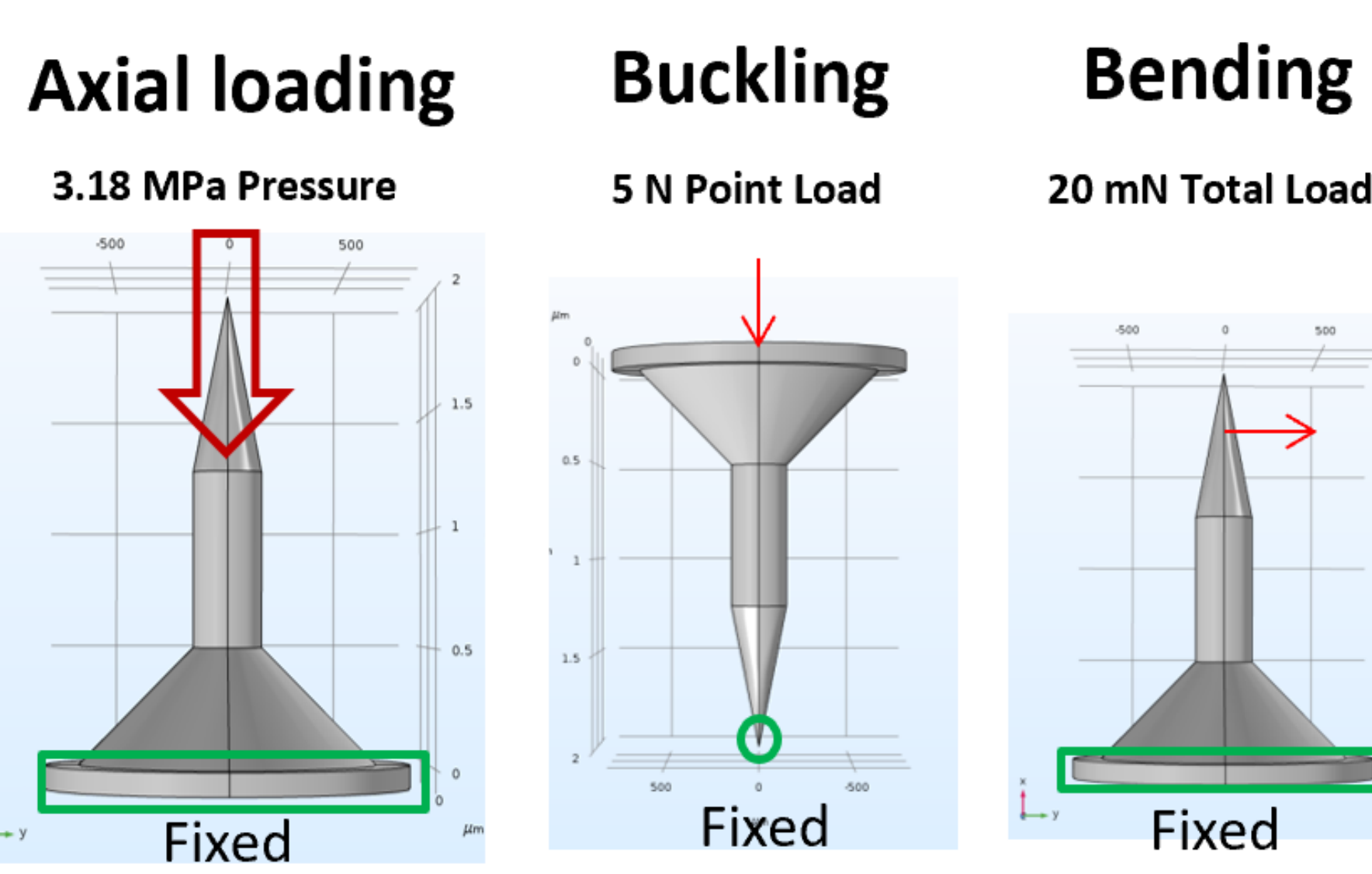
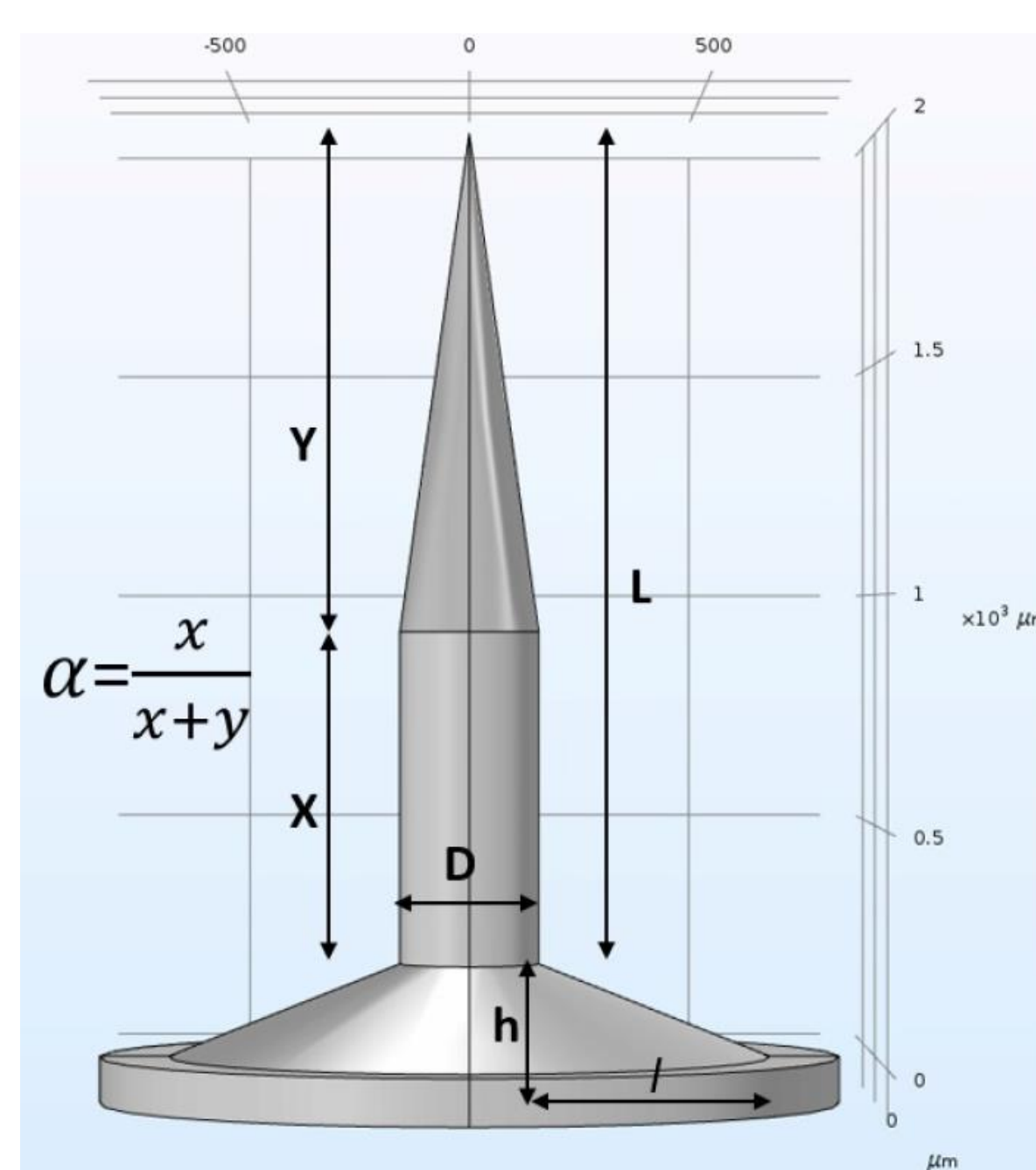

Figure 1. Illustration of the design parameters considered in this study.

Figure 2. Specified boundary conditions for each type of analysis.

Parameter name	Parameter value list	Parameter unit
alpha	range(0.1,0.1,0.9)	
D	150,300,450	um
l	10,100,200,300,400	um
h	10,200,400,600	um
L	1000,1500,2000,2500	um

Table 1. Considered levels for each design parameter.

RESULTS: Effect of each design parameter on maximum stress and deflection under bending and axial loadings as well as critical buckling load factor were examined.

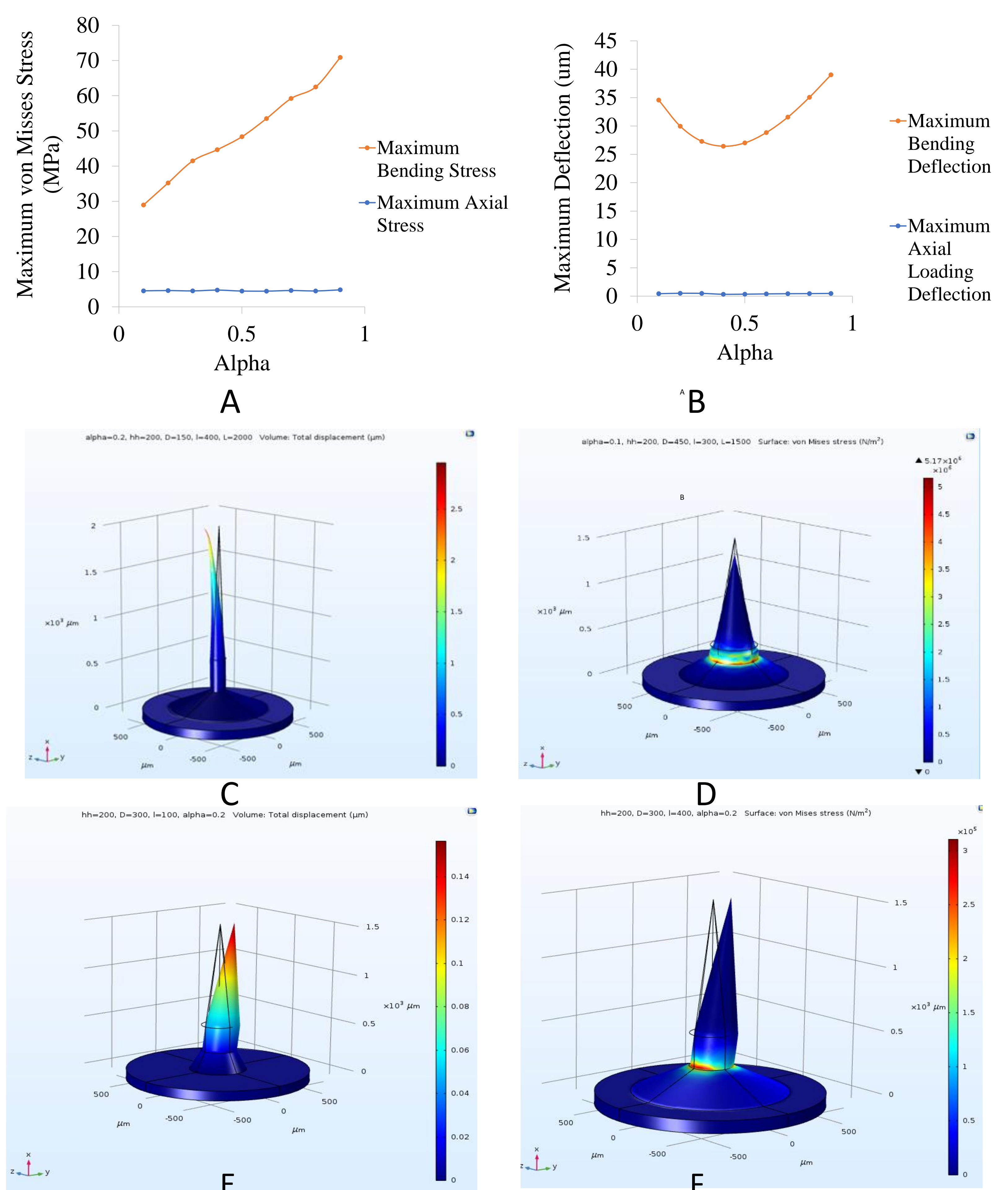

Figure 3. Effect of parameter alpha on (A) maximum stresses, and (B) maximum deflection under bending and axial loading. Contours of von Mises stress for different designs, under (C) axial, and (E) bending, and maximum deflection for different designs under (D) axial, (F) bending loading (D).

Source	DF	Adj SS	Adj MS	F-Value	P-Value	Percentage of contribution	Ranking
Alpha	8	1.6454	0.20568	24.03	0.00000	3.330250	3
h	3	1.6356	0.5452	63.69	0.00000	3.310415	4
D	2	18.0386	9.01929	1053.69	0.00000	36.50969383	1
l	4	0.0418	0.01045	1.22	0.30000	0.084602198	5
L	3	9.7372	3.24573	379.19	0.00000	19.7078593	2
Error	2139	18.3092	0.00856				
Total	2159	49.4077					

Source	DF	Adj SS	Adj MS	F-Value	P-Value	Percentage of contribution	Ranking
Alpha	8	0.3918	0.049	7.82	0.00000	0.466507989	3
h	3	0.929	0.3097	49.46	0.00000	1.106140688	2
D	2	68.8091	34.4046	5494.37	0.00000	81.92954277	1
l	4	0.292	0.073	11.66	0.00000	0.347678236	4
L	3	0.1697	0.0566	9.03	0.00001	0.202058208	5
Error	2139	13.394	0.0063				
Total	2159	83.9857					

Table 2. Result of ANOVA with (left) and without (right) consideration of maximum deliverable drug volume as an objective function. ANOVA was performed using software Minitab®.

CONCLUSIONS: In this study, parametric sweep feature was used to establish an extensive database for performing single-variable, multi-objective optimization, and ANOVA analyses. Results provided insight into effect of each design parameter on overall mechanical stability of microneedle. Also, it was revealed that microneedle dimeter is the most important design factor.

REFERENCES:

- Khalkhali, Abolfazl, Morteza Sarmadi, and Ehsan Sarikhani. "Investigation on the best process criteria for lap joint friction stir welding of AA1100 aluminum alloy via Taguchi technique and ANOVA." Proceedings of the Institution of Mechanical Engineers, Part E: Journal of Process Mechanical Engineering 231, no. 2, 329-342 (2017)
- Shamloo, Amir, et al. "Accelerated full-thickness wound healing via sustained bFGF delivery based on a PVA/chitosan/gelatin hydrogel incorporating PCL microspheres." International journal of pharmaceutics 537.1-2, 278-289 (2018).
- Chiandussi, Giorgio, Marco Codegone, Simone Ferrero, and Federico Erminio Varesio. "Comparison of multi-objective optimization methodologies for engineering applications." Computers & Mathematics with Applications 63, no. 5, 912-942 (2012).