

3D Simulation of an Acceleration Sensor with Self-sufficient Energy Supply

L. Weber¹, L. Fromme¹, D. Zielke²

¹University of Applied Sciences Bielefeld, Department of Engineering Sciences and Mathematics, Bielefeld, Germany

²University of Applied Sciences Bielefeld, Institute BIFAM, Bielefeld, Germany

Abstract

Piezo buzzers are usually used as signaler. A piezo buzzer consists of a plate, made of piezoelectrical material, glued on a brass plate. If an alternating voltage is connected to the brass and the piezoelectric material, the buzzer generates a signal. But the buzzer can also be used to convert mechanical into electrical energy. If acceleration influences the buzzer, the structure is bent by its mass and a voltage can be measured between the connection pads.

Acceleration perpendicular to the buzzer (see Figure 1 z-axes) influences a voltage, which is proportional to the acceleration. The voltage can be used to calculate the acceleration. With a small, additional weight on the buzzer the voltage, and this means the useable electrical energy, becomes powerful enough to drive a small microprocessor to calculate the acceleration and store its value. So the complete sensor needs no extra energy sources. The entire energy needed is obtained from the acceleration. Therefore, the sensor can „sleep" for a long time while waiting for an acceleration.

The sensor only measures the correct value of the acceleration in the perpendicular direction. To measure accelerations in other directions the sensor needs to be optimized. The main question is: How is it possible to measure acceleration in any possible directions by using only one single buzzer? Experiments show that the sensor detects even accelerations from horizontal directions but it is impossible to understand the relationship between acceleration and voltage.

The MEMS Module with the predefined Multiphysics interface Piezoelectric Devices contains everything to build up a model of the buzzer (see Figure 1). The buzzer is fixed on the outer edge. In the first step the simulation is used to explain the observed behavior of the buzzer. To ease it off, the acceleration is simplified to a static force, which acts at the end of the lever. The simulated and the measured results are in good agreement.

With the help of the simulation it is possible to see how voltages arise when the buzzer is bent into any possible direction. This knowledge makes it possible to explain the observed behavior and to optimize the structure of the buzzer. Instead of building thousands of prototypes the only necessary thing to do is to manipulate the simulation.

The result looks simple. Just cut the piezoelectrical material into four areas and sum up the amount of voltages. However, the important thing is to realize that it is possible to measure accelerations into different directions and that it is not possible with a non-modified buzzer. The result is a modified buzzer which now can afford accelerations into any direction. This is verified by establishing a prototype which shows the anticipated reaction.

Figures used in the abstract

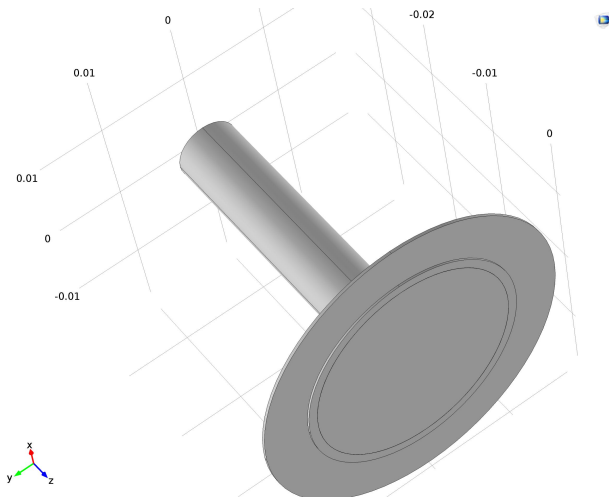

Figure 1