

First approach toward a modelling of the impedance spectroscopic behavior of microbial living cells

D. Raully¹, P. Xavier¹, E. Chamberod², J. M. F. Martins³, J. Angelidis⁴, H. Belbachir⁵

1. Grenoble Alps University, IMEP-LAHC, 3 Parvis Louis Néel, BP 257, 38016 Grenoble cedex 1, France.

2. Grenoble Alps University, IUT1, BP 67, 38402 St Martin d'Hères cedex, France.

3. CNRS-IRD, LTHE, Bâtiment OSUG-B, Domaine universitaire, BP 53, 38041 Grenoble cedex 09, France.

4. LEAS S.A., ZA La Bâtie, 175 Allée de Champrond, 38330 St Ismier, France LEAS, St Ismier, France.

5. HBA BIOTECH SA, 2 rue de l'ancien champ de mars, 38000 Grenoble, France.

Introduction: Interactions between electromagnetic (EM) fields and living cells is a strong issue for several decades [1]. EM fields may affect the development of the cells dealing with :

- level of the EM signal because non-thermal effects are suspected to exist, altering cell's metabolism.
- frequency of the EM signal because the spectral response of the living cell impedance exhibits some dispersion in relation with cell membrane behavior and shield effects [2].

In the battle against pathogenic microorganisms, electric current were proven to be effective in water [3-4]. Several mechanisms have been proposed for the inhibition, partially related to shape, dimensions and orientation of cells. This work examines this problem through the elaboration of an equivalent electric circuit of the popular bacteria *Escherichia coli* (Figure 1), supported by a COMSOL analysis using the AC/DC module. The internal current in the bacterium will be computed and an optimal frequency range which could be effective will be deduced.

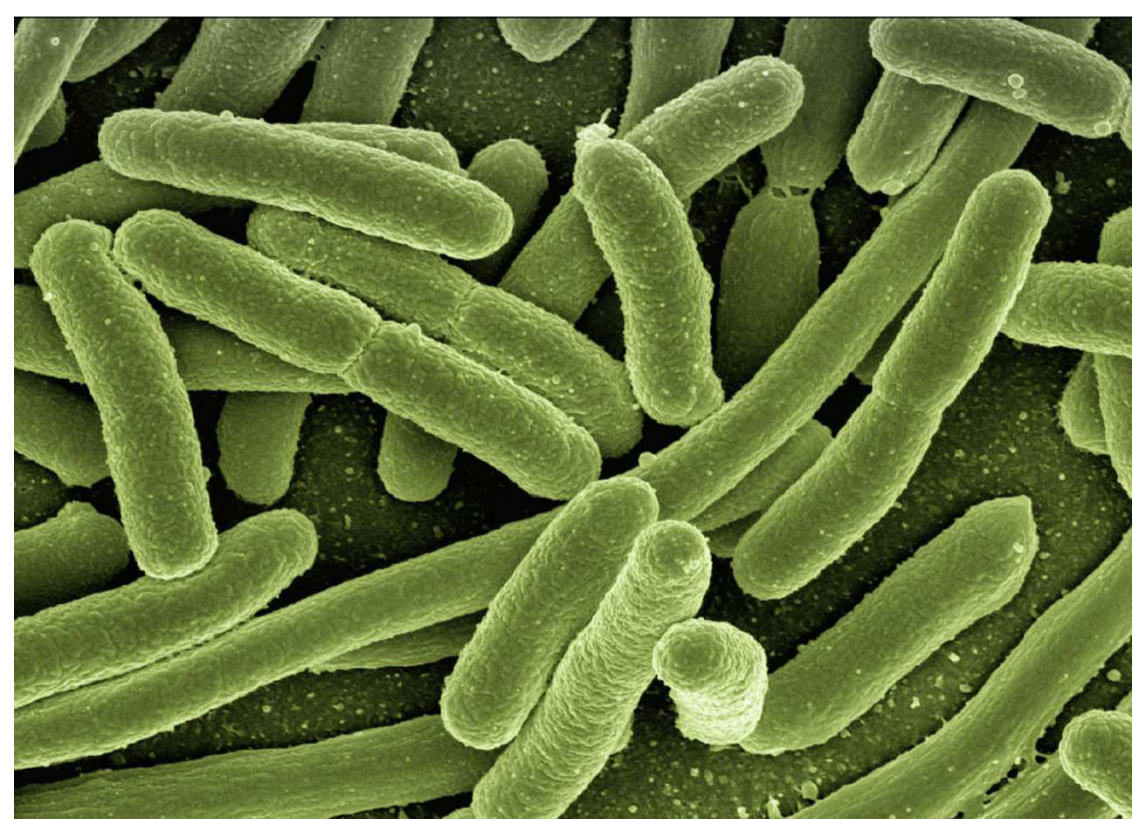

Figure 1. *Escherichia coli* (free photo from pixabay.com)

Computational Aspects: The model suitable for the required level of resolution is a 1-3 μm long, 0.3-0.7 μm wide, capsule filled with salted bound water and surrounded by a dielectric membrane of thickness 50nm. The medium is considered as a physiological fluid (free water). Figure 2 shows the COMSOL model, assuming that the field is provided through the application of an AC voltage between two plane parallel electrodes.

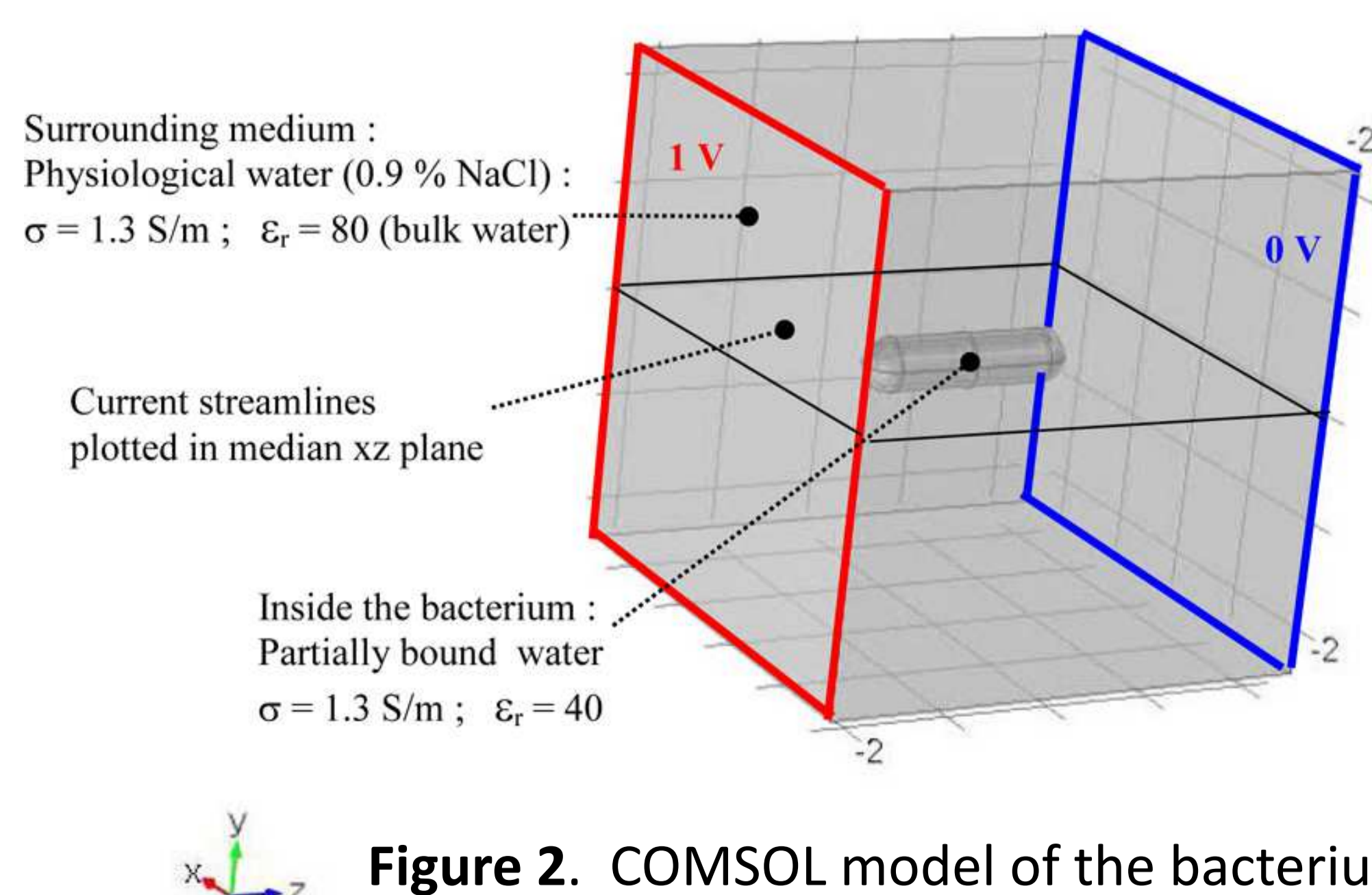

Figure 2. COMSOL model of the bacterium inside a box

Results: The equivalent circuit for the overall medium, containing the suspended bacterial cells, is deduced, taking into account the concentration and the orientation of bacteria, as well as the electrodes/medium interface (figure 3).

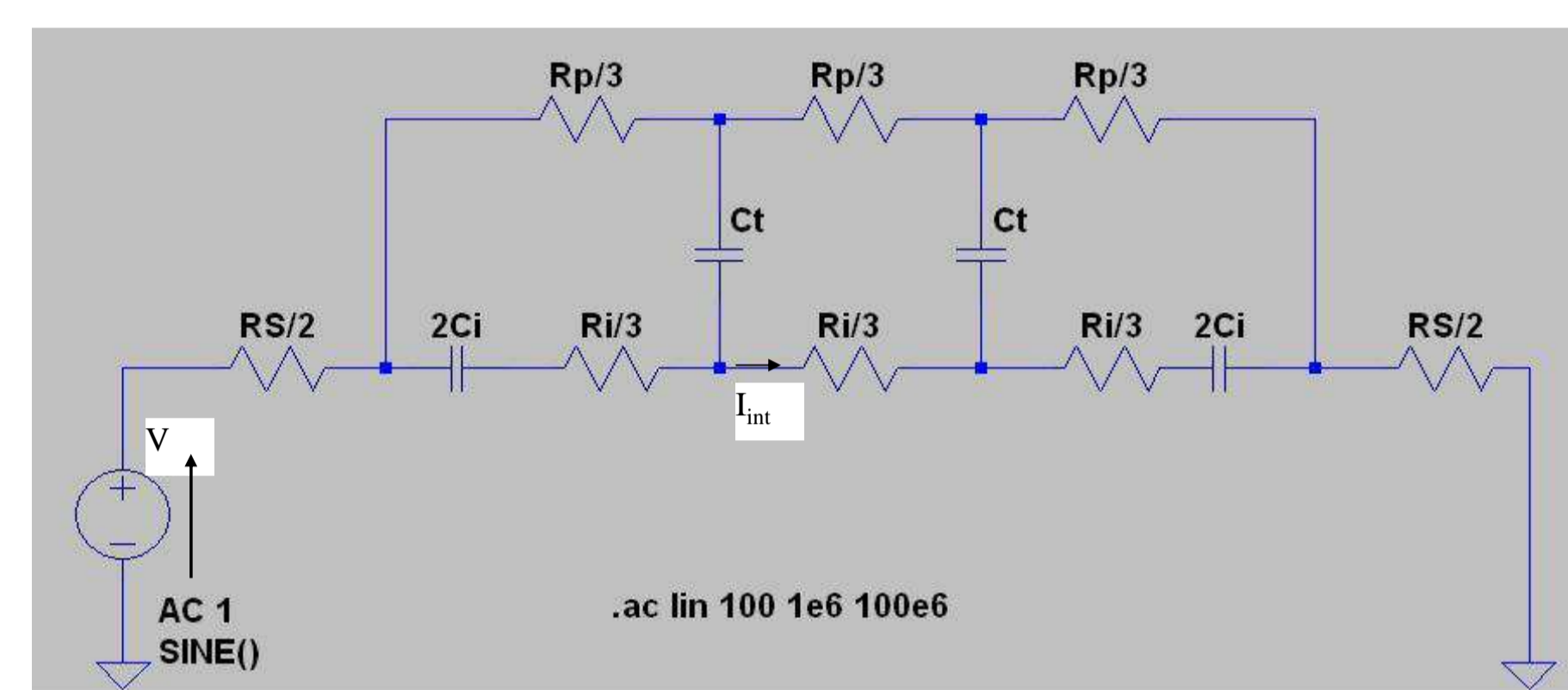

Figure 3. Equivalent circuit of the box, longitudinal Excitation

| | Bacterium in box, a=4.6 μm |
|-------|---------------------------------------|
| R_i | 10.5 M Ω |
| R_s | 104 k Ω |
| R_p | 62.4 k Ω |
| C_i | 1.15 fF |
| C_t | 15 fF |

Table 1. Parameters of the case indicated in Figure 3

Figure 4 shows the current lines for a bacterium longitudinally oriented with the electric field at a frequency of 1MHz. It reveals the well-known shield effect at lower frequencies.

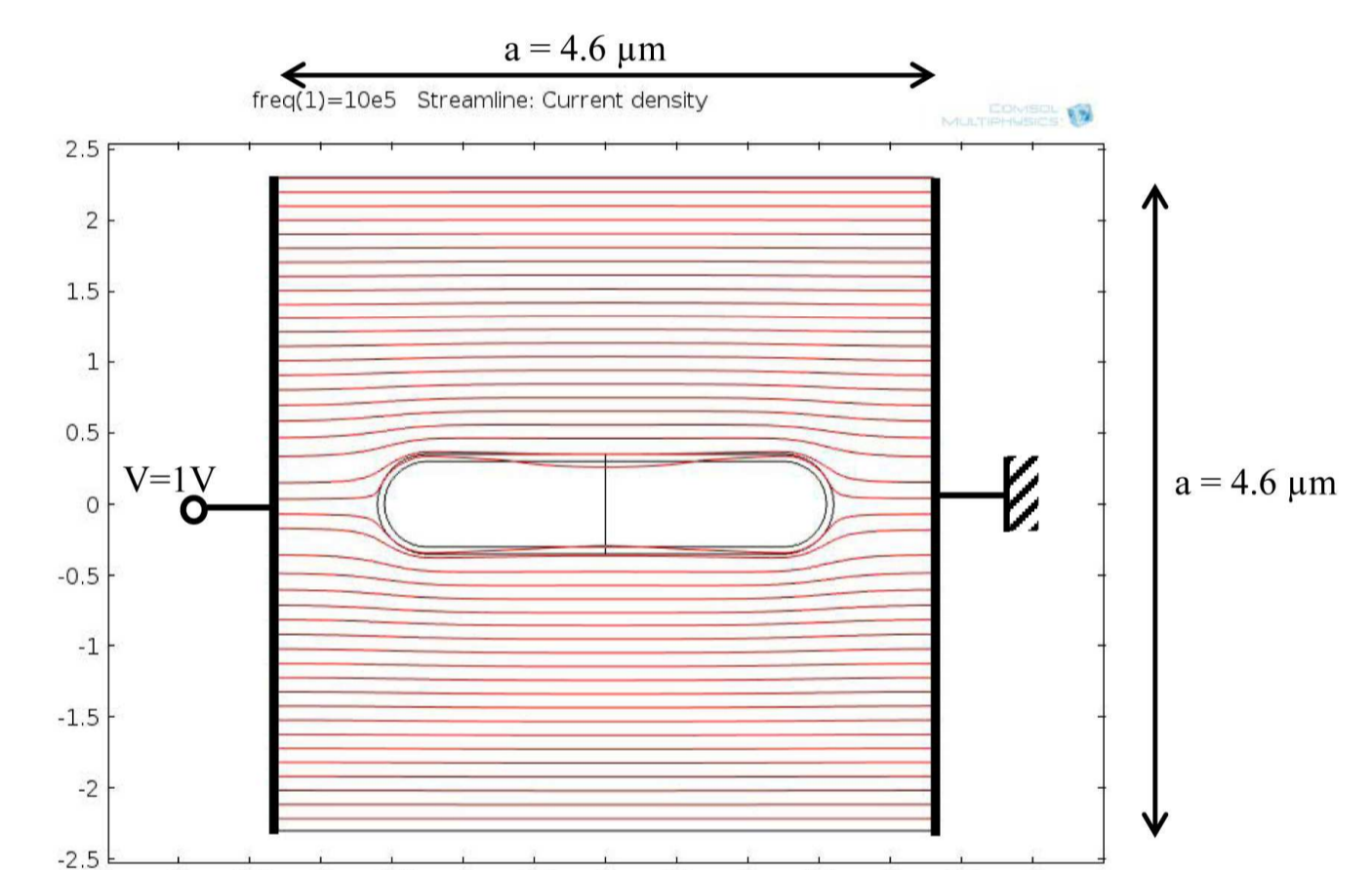

Figure 4. Current streamlines, longitudinal excitation @ f = 1MHz

Conclusions: The sensitivity to orientation and size for elongated microorganisms like *E. coli*. is computed and the existence of an optimal frequency for longitudinal orientation is found [5]. This work will be completed with a complex approach taking into account the microstructure of the dielectric membrane (mechanical vibrations of the proteins) and the electrochemical behavior of the electrodes/water interfaces.

References:

1. Cifra, M., J. Z. Fields, and A. Farhadi, Electromagnetic cellular interactions, Progr. In Biophys. & Molec. Biology, Vol. 105, 223-246 (2011).
2. Kell, D. B. and C. M. Harris, Dielectric spectroscopy and membrane organization, Journal of Bioelectricity, Vol. 4, No. 2, 317-348 (1985).
3. Spadaro, J. A., T. J. Berger, S. D. Barranco, S. E. Chapin, and R. O. Becker. Antibacterial effects of silver electrodes with weak direct current. Antimicrob. Agents Chemother. Vol. 6, 637-642 (1974).
4. Andreas Obermeier, Florian Dominik Matl, Wolfgang Friess and Axel Stemberger, Growth Inhibition of Staphylococcus aureus Induced by Low-Frequency Electric and Electromagnetic Fields, Bioelectromagnetics, Vol. 30, 270 – 279 (2009).
5. Giladi et al, Microbial Growth Inhibition by Alternating Electric Fields, Antimicrob Agents Chemother, Vol. 52(10), 3517–3522 (2008).