

Multiphysics Study Into Compression Rings, Coated Against Uncoated

M. Dickinson¹, N. Renevier², J. Calderbank³

¹The Jost Institute, School of Computing, Engineering & Physical Sciences, University of Central Lancashire, Preston, UK; Racing to Research Team, School of Computing, Engineering & Physical Sciences, University of Central Lancashire, Preston, UK

²The Jost Institute, School of Computing, Engineering & Physical Sciences, University of Central Lancashire, Preston, UK

³Racing to Research Team, School of Computing, Engineering & Physical Sciences, University of Central Lancashire, Preston, UK; School of Computing, Engineering & Physical Sciences, University of Central Lancashire, Preston, UK

Abstract

Over the past century the behavior of the piston ring while in operation has generated a considerable interest. In this study the KTM 520 engine has been used. This engine is a four stroke internal combustion engine. As this engine is typically used for motor cycle applications, it is an ideal choose for high RPM testing. To simulate the environment of running condition, the engine speed of 9,000 rpm was selected. This paper presents simulation results from COMSOL Multiphysics® to show how the compression ring performs when coated and uncoated. In this work the standard air cycle was employed, hence the ideal gas was used, which allowed for a cycle pressure plot. A thermal and dynamic analysis was carried out to enable an accurate behavior to represent the ring during operation (Figure 1). This paper will also present piston rings out of two materials studied in coated and uncoated conditions defining the optimum running conditions [1-3].

As the piston rises from bottom dead center to top dead center the interaction on the piston ring come from the lower contact of the groove where the ring sits and also the cylinder wall. However during operation the cylinder wall will also be lubricated allowing the ring to travel much more smoothly. Also during this time the piston ring will be inclined to twist hence linear continuous contact is not always the case. Therefore in the simulation the pressure acting on the ring caused by the piston has been calculated and is simply applied as a boundary condition.

To compensate for the pressure acting on the ring during operation ideal gas was used, also with the air standard Otto cycle to generate a pressure. To calculate the displacement of the piston during one cycle equations were used [3-6]. By using COMSOL Multiphysics® with heat and multi-body dynamic system, the piston ring with coating is shown with both gas pressure and heat boundaries. By using the variables tool within the software piston representation was used in equation form shown in (Figure 2).

Reference

- [1] D.Jones, T.Childs, C.Taylor, F.Martin, G.Zhu, D.Dowson, R.Chittenden, M.Priest, K.Holmes, and J.Bell, Engine Tribology (Elsevier, 1993).
- [2] M.Priest, D.Dowson, and C.M.Taylor, Wear 231 (1999) 89-101.
- [3] R.Stone and J.K.Ball, Automotive engineering fundamentals (SAE International, 2004).
- [4] M.Dickinson, N.Renevier, and W.Ahmed. The Refinement of the contact compression ring chamfer for race engine conditions. Comsol conference 2013. 5-9-2012. Comsol. 14-9-2012.
- [5] M.Dickinson, N.Renevier, and W.Ahmed. Optimising Piston Ring Contact Face Chamfer for High Performance Engines. SAE 2013 World Congress & Exhibition. 2013-01-0965. 8-4-2013. SAE. 16-4-2013.
- [6] M.Dickinson, N.Renevier, and J.Calderbank. A Study into the Compression Ring Rotation Based on Geometry. 1-4-2014.

Figures used in the abstract

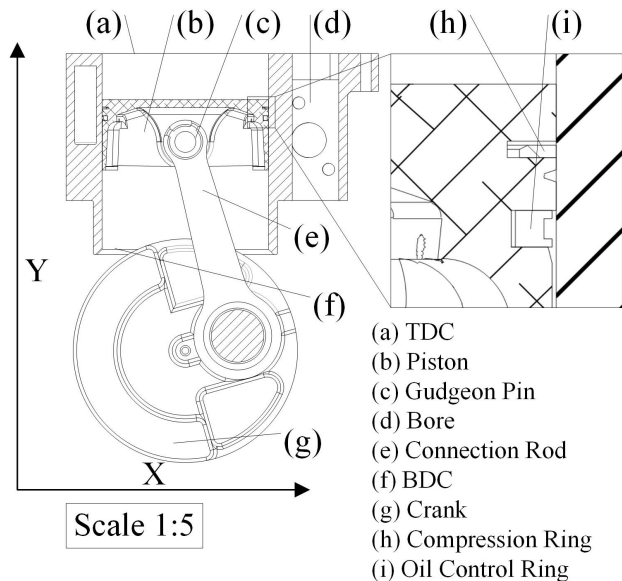

Figure 1: Figure 1 - piston engine system

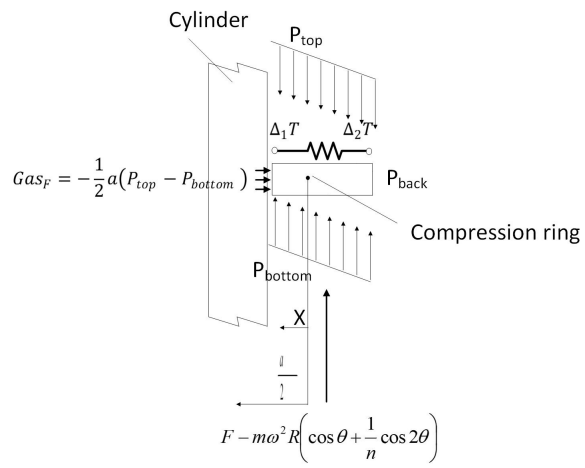

Figure 2: Figure 2 - Model and variables